

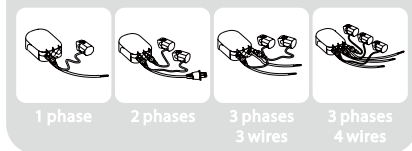

HOME ENERGY METER GEN6

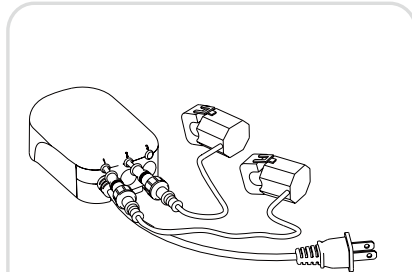

View the expanded manual:
<http://aeotec.com/support>



① Aeotec by Aeon Labs Home Energy Meter.

You hear a lot about energy use these days. About how if you reduce the amount of energy you use you'll both save money and the environment. But saving money by using less electricity is only possible if you understand when and how you are using it. That's what Aeotec's Home Energy Meters provide you with: understanding, for your whole home.

Installed in an electricity box, your new energy meter will monitor the total amount of electricity your home uses with accuracy and speed. Using a wireless Z-Wave® connection, it'll then feed the data it records back to your smart home's gateway. In near real-time you'll have a full understanding of how much electricity you use and when you use it.

② Familiarise yourself with your Home Energy Meter.

Your Home Energy Meter from Aeotec by Aeon Labs is comprised of two parts: the Main Body and Clamps. Once installed, the meter will sit near your home's main circuit box, while the clamps are attached to it.

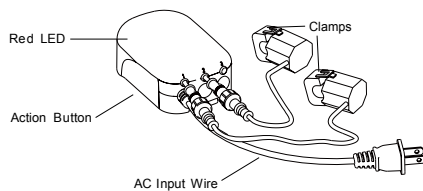

③ Quick start.

The installation of your Home Energy Meter has two major parts: the installation of it into your home's main circuit box and the syncing of it to your Z-Wave network. What follows are the instructions for both parts. Please note that only a licensed electrician, with knowledge and understanding of electrical systems and electrical safety, should perform the electrical installation of your meter into your home's circuit box. The syncing of your Home Energy Meter with your Z-Wave network can be performed by you.

Installing the meter into a circuit box.

Important: Only a licensed electrician should perform these steps.

Important: The circuit box's main breaker should be turned off to perform these installation steps.

The following diagrams highlight how the Home Energy Meter should be installed dependent on the region you are in;



In the United States, it is always a 2-phase installation;

Diagram of USA Version(2 Phases):

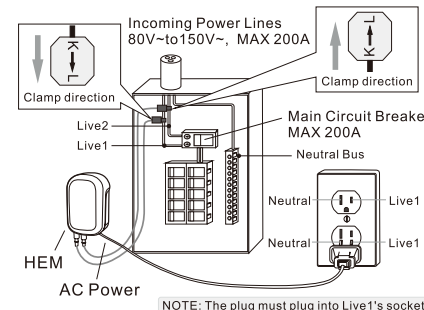

NOTE: The plug must plug into Live1's socket.

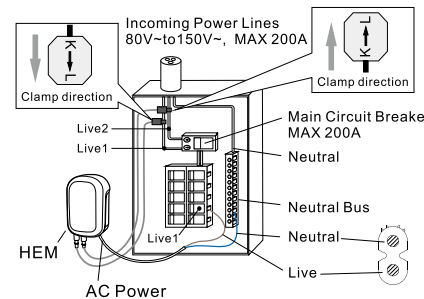

In 230 volt countries with a 1 phase installation;

Diagram of EU/AU Version(1 Phase):

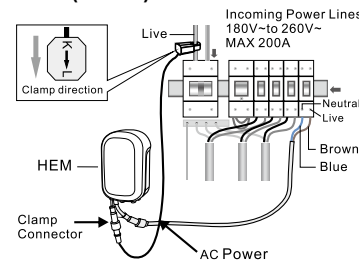

In 230 volt countries with a 3 phases and 3 wires installation;

Diagram of EU/AU Version(3 Phases,3 Wires):

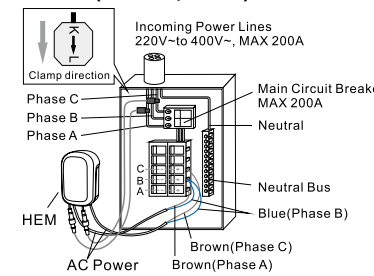

In 230 volt countries with a 3 phases and 4 wires installation;

Diagram of EU/AU Version(3 Phases,4 Wires):

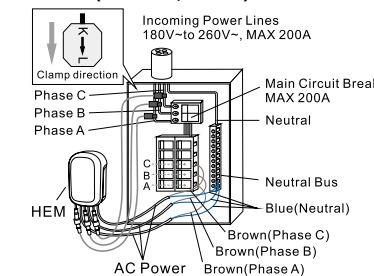

To perform the electrical installation for your Home Energy Meter (HEM), utilize the previous images to determine the phase version of the HEM and to also illustrate the following steps 3 through 7.

1. Turn off the home's main electricity breaker and open the main circuit box panel.
2. Connect each clamp to the HEM using the clamp connector and screw them tight.
3. Clip the clamps of the HEM around the incoming electricity cables that connect to the main circuit breaker.
4. Connect AC Wire to the meter using the AC Wire Connector.
5. Insert the HEM's neutral AC Wire into the main circuit breaker's neutral bus terminal.
6. Insert the HEM's live AC Wire into the main circuit breaker's live terminal.
7. Replace the main circuit box panel.
8. Turn the main breaker back on.

It is now time to permanently affix the Home Energy Meter to a surface. Within each meter is a low-frequency radio antenna that's used for wireless communication. This must be

taken into consideration when selecting a final location for the meter. Thick concrete walls, metals, or motor devices will affect the signal strength of the controller and the meter. If the home's circuit box is made of a metal, it is recommended that the Main Body of the meter be installed outside of the circuit box. Placing the meter inside the circuit box could degrade the quality of the radio signal and negatively impact its wireless range. To assist with such an installation, each meter is weatherised to the IP44 international standard. This makes it resistant to rain and snow when installed vertically.

To place the Home Energy Meter (HEM):

1. Remove the backing plate from the back of the HEM.
2. Affix the plate to the selected wall space using the provided screws. The plate should be installed vertically and aligned so that the wires of the HEM are at the bottom.
3. Attach the HEM to the backing plate.

Adding your meter to an existing Z-Wave network.

The electrical installation of your Home Energy Meter (HEM) is now complete. You must now wirelessly add it to your Z-Wave network.

1. Put your primary Z-Wave controller, usually a gateway or hub, into inclusion mode. If you are not sure how to do this, please refer to your controller's user manual.
2. Press the Action Button on your HEM. If it has been successfully added to your network, its LED will remain illuminated. If the adding was unsuccessful, your HEM's LED will continue to blink.

The installation of your Home Energy Meter is now complete. The next step is to set up your Home Energy Meter within the interface of your primary Z-Wave controller. This will allow you to visualize and utilize the energy consumption data that your meter collects.

Your Home Energy Meter can report wattage energy usage or KWH energy usage to your primary controller. As each controller is different, please refer to your controller's user manual for further information on monitoring and visualizing this data. The Z-Wave commands supporting energy monitoring are the Meter Command Classes.

④ Advanced.

Removing your meter from a Z-Wave network.

Your Home Energy Meter (HEM) can be removed from your Z-Wave network at any time. You'll need to use your Z-Wave network's primary to do this.

1. Put your main controller into its device removal mode. If you are unsure how to do this, please refer to your controller's user manual.
2. Press the Action Button on your HEM. If it has been successfully removed from your network, its LED will blink. If the removal was unsuccessful, its LED will be solid and it will be then repeated again.

Resetting your Home Energy Meter.

At some stage or your primary controller is missing or inoperable, you may also wish to reset all of your Home Energy Monitor's settings to their factory defaults. To do this, press and hold the action button for 10 seconds and then release it. Your HEM will now be

reset to its original settings and the LED on the HEM will begin to blink slowly to confirm a success.

Associating your Home Energy Meter to Report Automatically.

Your Home Energy Meter can send Wattage and KWH usage reports to associated devices. To enable this, please refer to your controller's manual on how to configure settings on Z-Wave devices linked to your controller. Initially, the meter is set up to report Watt and KWH reports.

Some gateways/controllers will automatically configure devices enabling you to take full advantage of the Home Energy Meter's features. Others may not perform any automatic configuration. In such a case you can choose to manually configure your meter to output the data that you wish to view.

Setting automatic report flags.

Parameter 101-103 [4 byte dec] can be configured through your gateway in case that the default settings of your meter are not what you desire.

Decimal Flag	Report Total HEM:	Decimal Flag	Report Watt for Clamps:
1	Report KWH	256	Clamp 1
2	Report Watt	512	Clamp 2
4	Report Voltage	1024	Clamp 3
8	Report Current		
Decimal Flag	Report KWH for Clamps:	Decimal Flag	Report Voltage (V) for Clamps:
2048	Clamp 1	65536	Clamp 1
4096	Clamp 2	131072	Clamp 2
8192	Clamp 3	262144	Clamp 3
Decimal Flag	Report Current (A) for Clamps:	Decimal Flag	
524288	Clamp 1		
1048576	Clamp 2		
2097152	Clamp 3		

The table above shows a decimal representation of all flags that can be set on parameter 101-103 to report specific data.

Example use of the Report Table.

For example, if you want to report only the total KWH consumption, and the Wattage for clamp 3, you would add 1 + 1024 and set the sum (1025) to parameter 101, 102, or 103. As another example, if you want to report Wattage and KWH power consumptions for all clamps, you would add 256 + 512 + 1024 + 2048 + 4096 + 8192, then set the sum (16128) to parameter 101, 102, or 103.

And if you want to report everything, you would add the whole table together and set it to 101, 102, or 103.

Setting an automatic report interval.

Parameter 111-113 [4 byte dec] can be configured through your gateway in case the default settings of your HEM is not what you desire.

Parameter 111 will set the interval for Group 1 (parameter 101), parameter 112 will set the

interval for Group 2 (parameter 102), and parameter 113 will set the interval for Group 3 (parameter 103).

As an example, you have set parameter 101 to report the total KWH consumption and the wattage for clamp 3, and you want to report it every 500 seconds. Set parameter 111 to 500 to accomplish this.

Utilizing different groups.

Your Home Energy Meter has 3 different groups that you may setup, from the settings and examples above, you may configure each group to report different clamps and total reports to report at different interval. Group 1 uses Parameter 101 and 111, group 2 uses parameter 102 and 112, and group 3 uses parameter 103 and 113.

⑤ Technical specifications.

Model number: ZW095

Input: 120V~, 60Hz, 20mA (USA version, 2P)

230V~, 50Hz, 10mA (EU/AU version, 1P/3P4)

380V~, 50Hz, 18mA (EU/AU version, 3P3)

Measure range of voltage:

80V~ to 150V~ (USA version, 2P)

180V~ to 260V~ (EU/AU version, 1P/3P4)

220V~ to 400V~ (EU/AU version, 3P3)

Measure range of current: 0A to 200A.

Operating distance: Up to 300 feet/100 metres outdoors.

Operating temperature: 0°C to 40°C.

Relative humidity: 8% to 80%.

⑥ Warranty.

If you are in need of any technical support during or subsequent to your products' warranty, please get in touch with our support team via <http://aeotec.com/support>. The Company you bought this product from has also guaranteed to assist you with any of your support needs, and you can also contact them for accordingly.

This guarantee made by the company who you purchased the product from includes the transfer of Aeon Labs' full warranty to that Company. They've guaranteed that they'll be able to assist you, the Customer, with all technical support and repair needs on our behalf.

Aeon Labs warrants to the original purchaser of Products, that is the Company who you have purchased from, that for the Warranty Period (as defined below), the Products will be free from material defects in materials and workmanship. The foregoing warranty is subject to the proper installation, operation and maintenance of the Products in accordance with installation instructions and the operating manual supplied. Warranty claims must be made to the Company who you have purchased from in writing within thirty (30) days of the manifestation of a problem.

Aeon Labs' sole obligation under the foregoing warranty is, at Aeon Labs' option, to repair, replace or correct any such defect that was present at the time of delivery, or to remove

the Products and to refund the purchase price to Company.

The Warranty Period begins on the date the Products is delivered and continues for 12 months. Any repairs under this warranty must be conducted by an authorized Aeon Labs service representative and under Aeon Labs' RMA policy. Any repairs conducted by unauthorized persons shall void this warranty.

Excluded from the warranty are problems due to accidents, acts of God, civil or military authority, civil disturbance, war, strikes, fires, other catastrophes, misuse, misapplication, storage damage, negligence, electrical power problems, or modification to the Products or its components.

Aeon Labs does not authorize any person or party to assume or create for it any other obligation or liability in connection with the Products except as set forth herein. Aeon Labs will pass on to Company all manufacturers' Material warranties to the extent that they are transferable, but will not independently warrant any Material. Company will assist Customer with all warranty, repair, return and technical support needs, Company must prepay shipping and transportation charges for returned Products, and insure the shipment or accept the risk of loss or damage during such shipment and transportation. Aeon Labs will ship the repaired or replacement products to Company freight prepaid. Customer and Company shall indemnify, defend, and hold Aeon Labs and Aeon Labs' affiliates, shareholders, directors, officers, employees, contractors, agents and other representatives harmless from all demands, claims, actions, causes of action, proceedings, suits, assessments, losses, damages, liabilities, settlements, judgments, fines, penalties, interest, costs and expenses (including fees and disbursements of counsel) of every kind (i) based upon personal injury or death or injury to property to the extent any of the foregoing is proximately caused either by a defective product (including strict liability in tort) or by the negligent or willful acts or omissions of Customer or its officers, employees, subcontractors or agents, and/or (ii) arising from or relating to any actual or alleged infringement or misappropriation of any patent, trademark, mask work, copyright, trade secret or any actual or alleged violation of any other intellectual property rights arising from or in connection with the products, except to the extent that such infringement exists as a result of Aeon Labs' manufacturing processes.

IN NO EVENT SHALL AEON LABS BE LIABLE FOR ANY INDIRECT, INCIDENTAL, PUNITIVE, SPECIAL OR CONSEQUENTIAL DAMAGES, OR DAMAGES FOR LOSS OF PROFITS, REVENUE, OR USE INCURRED BYCUSTOMER, COMPANY OR ANY THIRD PARTY, WHETHER IN AN ACTION IN CONTRACT, OR TORT, OR OTHERWISE EVENIF ADVISED OF THE POSSIBILITY OF SUCH DAMAGES. AEON LABS' LIABILITY AND CUSTOMER'S EXCLUSIVE REMEDY FOR ANY CAUSE OF ACTION ARISING IN CONNECTION WITH THIS AGREEMENT OR THE SALE OR USE OF THE PRODUCTS, WHETHER BASED ON NEGLIGENCE, STRICT LIABILITY, BREACH OF WARRANTY, BREACH OF AGREEMENT, OR EQUITABLE PRINCIPLES, IS EXPRESSLY LIMITED TO, AT AEON LABS' OPTION, REPLACEMENT OF, OR REPAYMENT OF THE PURCHASE PRICE FOR THAT PORTION OF PRODUCTS WITHRESPECT TO WHICH DAMAGES ARE CLAIMED. ALL CLAIMS OF ANY KIND ARISING IN CONNECTION WITH THIS AGREEMENT OR THE SALE OR USE OF PRODUCTS SHALL BE DEEMED WAIVED UNLESS MADE IN WRITING WITHIN THIRTY (30) DAYS FROM AEON LABS' DELIVERY, OR THE DATE FIXED FOR DELIVERY IN THE EVENT OF NONDELIVERY. THE

INDEMNITY AND WARRANTY IN ABOVE ARE EXCLUSIVE AND IN LIEU OF ALL OTHER INDEMNITIES OR WARRANTIES, WHETHER EXPRESS OR IMPLIED, INCLUDING THE IMPLIED WARRANTIES OF MERCHANTABILITY AND FITNESS FOR A PARTICULAR PURPOSE.

FCC NOTICE (for USA)

THE MANUFACTURER IS NOT RESPONSIBLE FOR ANY RADIO OR TV INTERFERENCE CAUSED BY UNAUTHORIZED MODIFICATIONS TO THIS EQUIPMENT. SUCH MODIFICATIONS COULD VOID THE USER'S AUTHORITY TO OPERATE THE EQUIPMENT.

STORE INDOORS WHEN NOT IN USE. SUITABLE FOR DRY LOCATIONS. DO NOT IMMERSE IN WATER. NOT FOR USE WHERE DIRECTLY EXPOSED TO WATER.

This device complies with Part 15 of the FCC Rules. Operation is subject to the following two conditions:

- 1 This device may not cause harmful interference, and
- 2 This device must accept any interference received, including interference that may cause undesired operation. This equipment has been tested and found to comply with the limits for a Class B digital device, pursuant to part 15 of the FCC Rules. These limits are designed to provide reasonable protection against harmful interference in a residential installation. This equipment generates, uses and can radiate radio frequency energy and, if not installed and used in accordance with the instructions, may cause harmful interference to radio communications. However, there is no guarantee that interference will not occur in a particular installation. If this equipment does cause harmful interference to radio or television reception, which can be determined by turning the equipment off and on, the user is encouraged to try to correct the interference by one or more of the following measures:

- Reorient or relocate the receiving antenna.
- Increase the separation between the equipment and receiver.
- Connect the equipment into an outlet on a circuit different from that to which the receiver is connected.
- Consul the dealer or an experienced radio/TV technician for help.

Warning

Do not dispose of electrical appliances as unsorted municipal waste, use separate collection facilities.

Contact your local government for information regarding the collection systems available.

Certifications (regional):



Z-Wave and Z-Wave Plus are registered trademarks of Sigma Designs and its subsidiaries in the United States and other countries



symbols	Description
	This product has been tested to the requirements of CAN/CSA-C22.2 No. 61010-1, second edition, including Amendment 1, or a later version of the same standard incorporating the same level of testing requirements
	Double insulation or reinforced insulation
	Caution, risk of danger
	CONFORMS TO UL STD 61010-1; CERTIFIED TO CSA STD C22.2 NO.61010-1 and IEC STD 61010-2-032
CAT II	For measurements performed on circuits directly connected to the low voltage installation

Version:501009500002-AA

www.aeotec.com



Association information

5.2 Association Command Class

The HEM supports 1 association group and can add max 5 association nodes in association group 1. Automatic REPORTs (configured via parameter 101/102/103) can be sent to the associated nodes in association group 1.

5.3 Association Group Info Command Class

5.3.1 Association Group Info Report Command Class

Profile: General: NA (Profile MSB=0, Profile LSB=1)

5.3.2 Association Group Name Report Command Class

Group 1: Lifeline

Configuration parameters information

Parameter Number	Description	Default Value	Size
2	For parameters of 101 - 103, power, energy detection mode configuration: 0 = Report power, energy absolute value; 1 = Report positive/negative power, report the algebraic sum energy; 2 = Report positive/negative power, only report energy positive part (consuming electricity); 3 = Report positive/negative power, only report energy negative part (generating electricity).	0	1
3	Enable selective reporting only when power change reaches a certain threshold or percentage set in 4-11 below. This is used to reduce network traffic. 0 = Disable 1 = Enable	1	1
4	Threshold change in wattage to induce an automatic report (Whole HEM). (Valid values 0-60000)	50(W)	2
5	Threshold change in wattage to induce an automatic report (Clamp 1). (Valid values 0-60000)	50(W)	2
6	Threshold change in wattage to induce an automatic report (Clamp 2). (Valid values 0-60000)	50(W)	2

7	Threshold change in wattage to induce an automatic report (Clamp 3). (Valid values 0-60000)	50(W)	2
8	Percentage change in wattage to induce an automatic report (Whole HEM). (Valid values 0-100)	10 (%)	1
9	Percentage change in wattage to induce a automatic report (Clamp 1). (Valid values 0-100)	10 (%)	1
10	Percentage change in wattage to induce an automatic report (Clamp 2). (Valid values 0-100)	10 (%)	1
11	Percentage change in wattage to induce an automatic report (Clamp 3). (Valid values 0-100)	10 (%)	1
13	Enable/disable reporting CRC-16 Encapsulation Command. 0 = Disable 1 = Enable	1	1
100	Set 101-103 to default.	N/A	1
101	Configure which report needs to be sent in Report group 1 (See flags in table below).	0x00 00 00 02	4
102	Configure which report needs to be sent in Report group 2 (See flags in table below).	0x00 00 00 01	4
103	Configure which report needs to be sent in Report group 3 (See flags in table below).	0	4
110	Set 111-113 to default.	N/A	1
111	Set the interval time of sending report in Report group 1 (Valid values 0x01-0x7FFFFFFF).	0x00 00 00 05	4
112	Set the interval time of sending report in Report group 2 (Valid values 0x01-0x7FFFFFFF).	0x00 00 00 78	4
113	Set the interval time of sending report in Report group 3 (Valid values 0x01-0x7FFFFFFF).	0x00 00 00 78	4
200	Partner ID 0 = Aeon Labs Standard Product 1 = Others	0	1
252	Enable/disable to lock configuration parameters 0 = Disable 1 = Enable.	0	1
255	1. Value=0x55555555, Default=1, Size=4 Reset to factory default setting and removed from the z-wave network 2. Reset to factory default setting	N/A	4 1

	7	6	5	4	3	2	1	0
Configuration Value 1(MSB)	Reserved							
Configuration Value 2	Reserved		Multi Channel Meter REPORT (A) on Clamp 3	Multi Channel Meter REPORT (A) on Clamp 2	Multi Channel Meter REPORT (A) on Clamp 1	Multi Channel Meter REPORT (V) on Clamp 3	Multi Channel Meter REPORT (V) on Clamp 2	Multi Channel Meter REPORT (V) on Clamp 1
Configuration Value 3	Reserved		Multi Channel Meter REPORT (kWh) on Clamp 3	Multi Channel Meter REPORT (kWh) on Clamp 2	Multi Channel Meter REPORT (kWh) on Clamp 1	Multi Channel Meter REPORT (Watt) on Clamp 3	Multi Channel Meter REPORT (Watt) on Clamp 2	Multi Channel Meter REPORT (Watt) on Clamp 1
Configuration Value 4(LSB)	Reserved	Reserved	Reserved	Meter REPORT (A) of whole Clamps	Meter REPORT (V) of whole Clamps	Meter REPORT (Watt) of whole Clamps	Meter REPORT (kWh) of whole Clamps	