

Siren 6 user guide.

Modified on: Tue, 2 Jul, 2019 at 12:23 PM

Aeotec Siren 6.

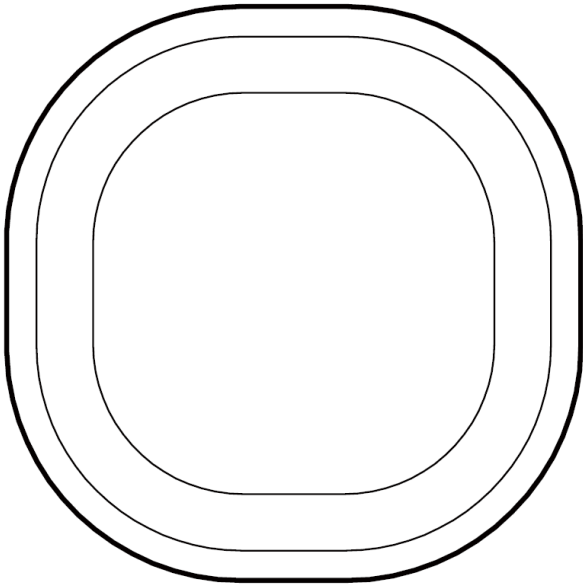

Aeotec Siren 6 (<https://aeotec.com/z-wave-siren>), has been crafted to power connected lighting using **Z-Wave Plus** (<http://aeotec.com/z-wave-plus>). It is powered by Aeotec's **Gen5** (<http://aeotec.com/z-wave-gen5>) technology and features **Z-Wave S2** (<https://aeotec.com/z-wave-s2>).

To see whether Siren 6 is known to be compatible with your Z-Wave system or not, please reference our **Z-Wave gateway comparison** (<http://aeotec.com/z-wave-gateways>) listing. The **technical specifications of Siren 6** (<https://aeotec.freshdesk.com/solution/articles/6000212170-siren-6-technical-specifications->) can be viewed at that link.

Get to Know your Siren.

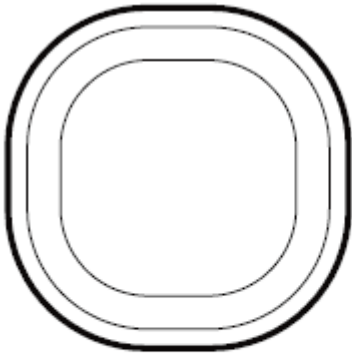

Chime-Front

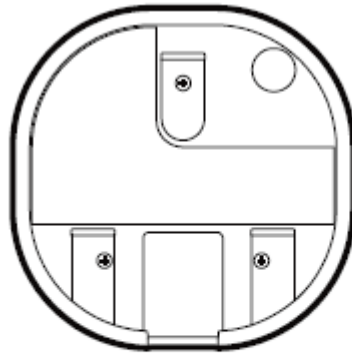

Chime-Back

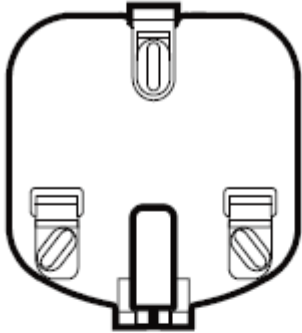

Wall Mount Plate

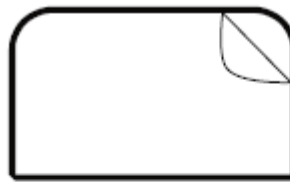

Double-sided tape



Screws (x 3)

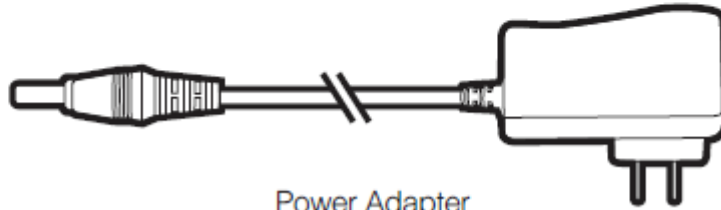

Power Adapter

Pre-loaded Tones.

Tone #	Name	Use
1	Ding Dong	Doorbell
2	Ding Dong Tubular Bell	Doorbell
3	Traditional Apartment Buzzer	Doorbell
4	Electric Apartment Buzzer	Doorbell
5	Westminster Chimes (Hearing Enhanced)	Doorbell
6	Chimes (Hearing Enhanced)	Doorbell
7	Cuckoo (Hearing Enhanced)	Doorbell
8	Traditional Bell	Doorbell
9	Smoke Alarm (Low)	Safety
10	Smoke Alarm (High)	Safety
11	Fire Evacuation Buzzer	Safety
12	Carbon Monoxide Sensor	Safety
13	Klaxon	Safety
14	Klaxon (Deep)	Safety
15	Warning Tone	Safety
16	Tornado Siren	Safety
17	Alarm	Security

18	Deep Alarm Tone	Security
19	Alarm (Archangel tone)	Security
20	Alarm (Shrill)	Security
21	Digital Siren	Security
22	Alert Series	Security
23	Security	Misc.
24	Clock Buzzer	Misc.
25	Christmas Tree	Misc.
26	Gong	Misc.
27	Single Bell Ting	Misc.
28	Tonal Pulse	Misc.
29	Upwards Tone	Misc.
30	Door Open	Misc.

Important safety information.

Please read this and other device guides carefully. Failure to follow the recommendations set forth by Aeotec Limited may be dangerous or cause a violation of the law. The manufacturer, importer, distributor, and / or reseller will not be held responsible for any loss or damage resulting from not following any instructions in this guide or in other materials.

Keep product away from open flames and extreme heat. Avoid direct sun light or heat exposure.

Siren 6 is intended for indoor use in dry locations only. Do not use in damp, moist, and / or wet locations.

Warning: to prevent possible hearing damage, test only when wearing appropriate hearing protection.

Quick Start.

Getting your Siren up and running is as simple as plugging it into a wall socket and linking it to your existing Z-Wave network. The following instructions tell you how to link your Siren to your Z-Wave network via using Aeotec by Aeon Labs' Z-Stick or Minimote controllers. If you are using other products as your main Z-Wave controller, such as a Z-Wave gateway, please refer to the part of their respective manual that tells you how add new devices to your network.

Install Mounting plate in the location of your choice.

1. Affix Siren 6 Wall Mount Plate in any desired location near an outlet.
 - a. Use 3x 20mm screws or double-sided tape.

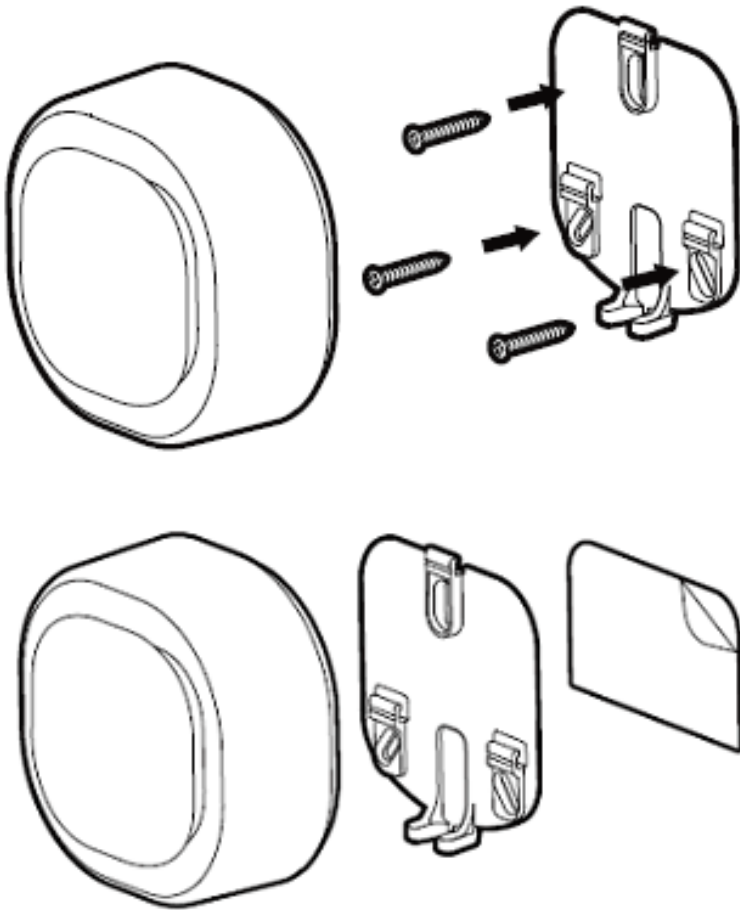

b. Lock the Siren 6 into place where the mount is installed.

Pairing your Siren 6 into your existing Z-Wave network.

1. Power Siren 6 through the provided power adapter.
2. Ensure that Siren 6 LED is blinking slowly.
3. Set your Z-Wave gateway into pair / add device mode. (Refer to your Z-Wave gateway/controller instruction manual on how to set it into pair mode).
4. Tap the Siren 6 Action Button once. (If your gateway supports S2 encryption, enter the first 5 digits of the DSK into your Z-Wave gateway interface to complete S2 encrypted pairing, DSK is printed on the Siren 6 unit).
5. If Siren 6 has successfully paired to your Z-Wave gateway, the LED on Siren 6 will emit a solid color for 30 seconds, then turn off. If in the case that the Siren 6 failed to pair, LED will continue to blink slowly.

With your Siren now working as a part of your smart home, you'll be able to configure it from your home control software. Please refer to your software's user guide for precise instructions on configuring Siren to your needs.

Advanced.

Removing your Siren from a Z-Wave network.

Your Siren can be removed from your Z-Wave network at any time. It is always advised that you use your gateway to perform an unpair in order to avoid leaving phantom / failed nodes that become difficult to remove. To do so, follow the steps below:

1. Place your gateway or controller into Z-Wave unpair or exclusion mode. (Please refer to your controller/gateway manual on how to do this)
2. Press the Action Button 6x times in 2 seconds on your Siren.
3. If your Siren has been successfully unpaired from your network, its LED will begin to blink slowly which indicates that it is ready to be paired again.

Test Siren 6 sound manually.

You will be able to manually test your Siren 6 unpaired or paired to a Z-Wave network, to determine if its sound is working, perform the button action listed below:

- Press and hold Action Button down for 2-5 seconds

Safety: Test only when wearing necessary ear protection. Siren 6's speaker emits tones up to 105dB that can cause hearing damage.

Reset your Siren.

This method is not fully advised unless your gateway has failed, and you do not yet have another gateway to perform a general unpair on Siren 6.

To do this, follow the steps below:

1. Press and hold the Action button for 20 seconds
2. [2-5 seconds], the test siren sound will run, then stop after 5 seconds has passed.
3. [5-20 seconds] The LED will continue to blink faster (5 to 10 seconds) and faster (10 to 20 seconds).
4. [21 seconds and later] The LED will then quickly flash 3 times then will have LED breath in and out as you hold down the Action Button
5. Release the Action button, and the Siren 6 will factory reset.

Upgrade Siren 6 to Doorbell 6.

You can upgrade Siren 6 to Doorbell 6 at any time, all you need is Aeotec Button which is a wireless addon button used for Siren/Doorbell 6. Siren 6/Doorbell 6 supports up to 3 Aeotec Buttons.

You can learn how to pair Aeotec Button to Siren 6 here:

<https://aeotec.freshdesk.com/solution/articles/6000202225-aeotec-button-user-guide->
(<https://aeotec.freshdesk.com/solution/articles/6000202225-aeotec-button-user-guide->)

More Advanced Configurations.

You can find more advanced configurations for Siren 6 in our Engineering Sheet section on our Freshdesk which can be used to integrate Siren 6 into a new gateway or software, or use it as a reference for configurations.

- **[More Advanced Configuration settings and function use.](https://aeotec.freshdesk.com/helpdesk/attachments/6086177008)**
(<https://aeotec.freshdesk.com/helpdesk/attachments/6086177008>)

Using Siren 6 with SmartThings hub.

krlaframboise has created a custom device handler to be used with SmartThings hub with all functions and use cases integrated. You can find instructions on how to install the custom device handler here and how to configure your Siren 6 to your needs:

- <https://aeotec.freshdesk.com/solution/articles/6000223183-aeotec-siren-6-with-smarththings-hub->
(<https://aeotec.freshdesk.com/solution/articles/6000223183-aeotec-siren-6-with-smarththings-hub->).

If you have paired Aeotec Button to Siren 6, you can now consider your Siren 6 a Doorbell 6 instead. If this is the case, please go to this link instead:

- <https://aeotec.freshdesk.com/solution/articles/6000223182-aeotec-doorbell-6-with-smarththings-hub->
(<https://aeotec.freshdesk.com/solution/articles/6000223182-aeotec-doorbell-6-with-smarththings-hub->).